



CARDIN ELETRONICA spa
 Via Raffaello, 36
 31020 San Vendemiano (TV) Italy
 Tel: +39/0438.404011-401818
 Fax: +39/0438.401831
 email (Italy): Sales.office.it@cardin.it
 email (Europe): Sales.office@cardin.it
 Http: www.cardin.it

ZVL414.05

DKS 250

This product has been tried and tested in the manufacturer's laboratory, during the installation of the product follow the supplied indications carefully.



TASTIERA A CODICE NUMERICO
NUMERICAL CODE KEYBOARD
CLAVIER À CODE NUMÉRIQUE
TASTATUR MIT NUMERISCHEM CODE
TECLADO DE CÓDIGO NUMÉRICO

ITALIANO

AVVERTENZE	Pagina	2
CARATTERISTICHE TECNICHE	Pagina	2
INSTALLAZIONE INTERFACCIA	Pagina	3
INSTALLAZIONE TASTIERA	Pagina	4
PROCEDURA DI PROGRAMMAZIONE	Pagina	5-6
MODALITÀ DI FUNZIONAMENTO	Pagina	7-9
NOTE	Pagina	10

DEUTSCH

ANWEISUNGEN	Seite	29
TECHNISCHE DATEN	Seite	29
SCHNITTSTELLEN-INSTALLATION	Seite	30
TASTATUR-INSTALLATION	Seite	31
PROGRAMMIERVERFAHREN	Seite	32-33
BETRIEBSWEISE	Seite	34-36
ANMERKUNGEN	Seite	37

ENGLISH

IMPORTANT REMARKS	Page	11
TECHNICAL SPECIFICATIONS	Page	11
INTERFACE INSTALLATION	Page	12
KEYBOARD INSTALLATION	Page	13
PROGRAMMING PROCEDURE	Page	14-15
OPERATING MODE	Page	16-18
NOTES	Page	19

ESPAÑOL

ADVERTENCIAS	Página	38
CARACTERÍSTICAS TÉCNICAS	Página	38
INSTALACIÓN DE LA INTERFAZ	Página	39
INSTALACIÓN DEL TECLADO	Página	40
PROCEDIMIENTO PARA LA PROGRAMACIÓN	Página	41-42
MODALIDAD DE FUNCIONAMIENTO	Página	43-45
NOTAS	Página	46

FRANÇAIS

REMARQUE	Page	20
CARACTÉRISTIQUES TECHNIQUES	Page	20
MISE EN PLACE DE L'INTERFACE	Page	21
MISE EN PLACE DU CLAVIER	Page	22
PROCÉDÉ DE PROGRAMMATION	Page	23-24
MODE DE FONCTIONNEMENT	Page	25-27
NOTES	Page	28

Prima di dar inizio all'installazione leggere attentamente il presente fascicolo. In particolare, prendere visione dei dispositivi di sicurezza previsti dal prodotto per utilizzarli con la massima efficacia. **Prima di procedere con la programmazione leggere attentamente le "NOTE" a pag. 10.** L'utilizzo dei prodotti e la loro destinazione ad usi diversi da quelli previsti e/o consigliati, non è stato sperimentato dal costruttore, pertanto i lavori eseguiti sono sotto la completa responsabilità dell'installatore.

Il presente manuale si rivolge a persone abilitate all'installazione di "apparecchi utilizzatori di energia elettrica" e richiede una buona conoscenza della tecnica, esercitata in forma professionale. Il costruttore declina ogni responsabilità per eventuali danni provocati dalla mancata osservanza nell'installazione delle norme di sicurezza attualmente in vigore.

Descrizione

Il sistema si compone di due elementi collegati fra loro via filo:

- **DKS250T** tastiera numerica da esterno,
- **DKS250R** interfaccia per collegamento seriale, che provvede anche all'alimentazione della tastiera.

La tastiera è costituita da una struttura metallica in zama, antiscasso, con verniciatura ad alta resistenza e tasti cromati antiusura. Di facile installazione è dotata di un grado di protezione **IP57** e di un sistema di fissaggio antiscasso con vite e chiave speciali.

Dotata inoltre di:

- LED rosso segnalazione
- LED verde segnalazione
- 10 tasti numerici (0-9)
- un tasto di conferma ★
- un tasto di annullamento operazione #
- 4 funzioni di canale (A, B, C, D)
- buzzer segnalazione sonora.

L'interfaccia, collocata in un contenitore da interno **IP20**, si collega alla tastiera con cavo telefonico (o equivalente) a due conduttori **Ø 0,6 mm**, lunghezza massima **150 m** dotata di tasto di programmazione e due LED **L1** verde **L2** rosso di segnalazione visiva.

Possibilità di impiego

Il sistema **DKS250** permette l'attuazione via filo di apparecchiature elettriche ed elettroniche, fornendo la massima sicurezza e trovando il suo miglior impiego nel comando di porte e portoni motorizzati.

Numero di codici utente memorizzabili (max 6 cifre ciascuno).....	250
Numero di combinazioni di codici disponibili.....	1 milione
Numero di tastiere collegabili in parallelo ad una interfaccia.....	3

CARATTERISTICHE TECNICHE

Alimentazione interfaccia DKS250R	12/24Vac-dc
Assorbimento:	
Tastiera.....	6mA
Interfaccia con tastiera	31mA
Interfaccia con tastiera e un relé attivo	54mA
Max potenza commutabile del relé con carico resistivo (escluse lampadine):	
Carico in ac/dc	60VA/24W
Tensione massima	30Vac-dc
Corrente massima	1 A
Ritardo all'attivazione del relé	80-100ms
Temperatura di esercizio tastiera/interfaccia	-10° ...+55°C

Dimensioni d'ingombro

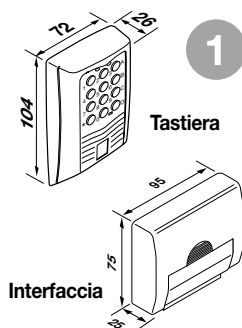

INSTALLAZIONE INTERFACCIA IN CASSETTA IP20

In base alla tipologia e alle caratteristiche d'impianto individuare il punto di posa del sistema.
L'interfaccia dovrà essere collocata:

- in ambiente interno (in contenitore stagno se installata all'esterno)
- al riparo da urti e manomissioni;
- in una posizione facilmente raggiungibile dal tecnico, per interventi di manutenzione.

Fissaggio:

- A muro, interasse **75 mm**, tramite due viti **M4** e relativi Fischer (non di nostra fornitura)
- In contenitore stagno utilizzando il biadesivo fornito di serie

Collegamento elettrico interfaccia



Attenzione! Alimentare l'interfaccia esclusivamente con un alimentatore di sicurezza.
L'utilizzo di alimentatori non di sicurezza può provocare pericolo.

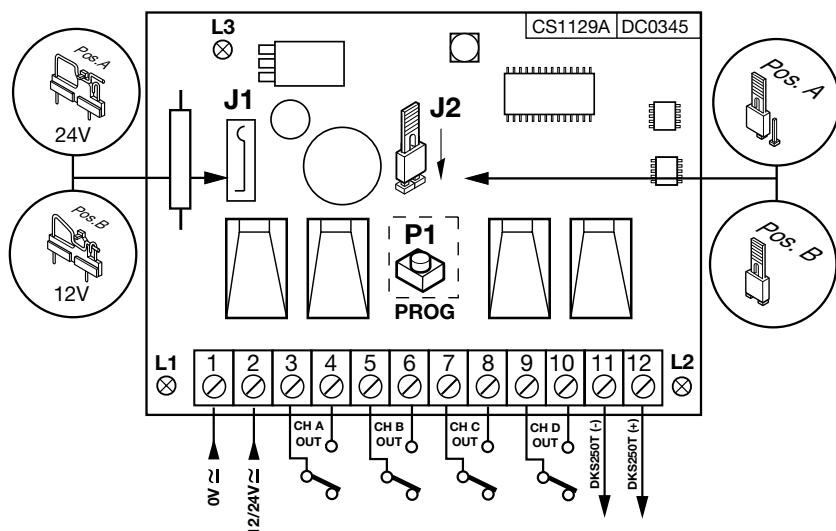

L'interfaccia (circuit stampato CS1129A/B) è dotata di contenitore da interno e di morsetteria a 12 vie con collegamento elettrico:

12V ac/dc tra i morsetti 1-2 con jumper "J1" in posizione "B"

24V ac/dc tra i morsetti 1-2 con jumper "J1" in posizione "A"

(L3 si accende quando l'apparecchiatura è sotto tensione)

L'interfaccia ha quattro relé le cui uscite (solo contatto N.A.) sono contrassegnate rispettivamente con CHA, CHB, CHC, e CHD.

- In base alla distanza tra l'interfaccia e la tastiera predisporre il cavetto di collegamento, che alimenta la tastiera a codice, sul quale avviene la comunicazione seriale dei dati.
- Collegare i cavi dei faston: **FS1** nero al morsetto "11"; **FS2** rosso al morsetto "12" (fig.3b)

INSTALLAZIONE TASTIERA ESTERNA IP57

1) Far passare i cavi di collegamento "1" provenienti dall'interfaccia attraverso il muro.

2) Forare il muro alla distanza indicata in figura 3a (58 mm).

3) Inserire i Fischer "2" forniti con il kit.

4) Bloccare la contropiastra "3" utilizzando le viti "4" fornite con il kit.

5) Collegare i faston dei cavi "1" ai faston della tastiera "5" (fig. 3a-3b):
- **filo rosso** dal tastierino al morsetto 12 dell'interfaccia
- **filo nero** dal tastierino al morsetto 11 dell'interfaccia

6) Infine posizionare la tastiera (fig 3b-3c) e bloccarla alla contropiastra utilizzando la vite speciale "S1" e l'apposito attrezzo "K1".

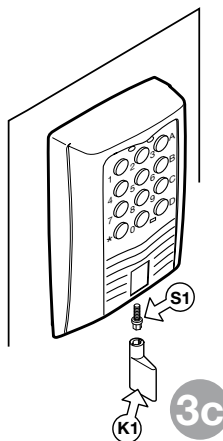
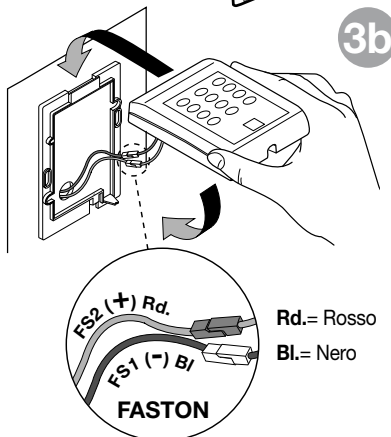
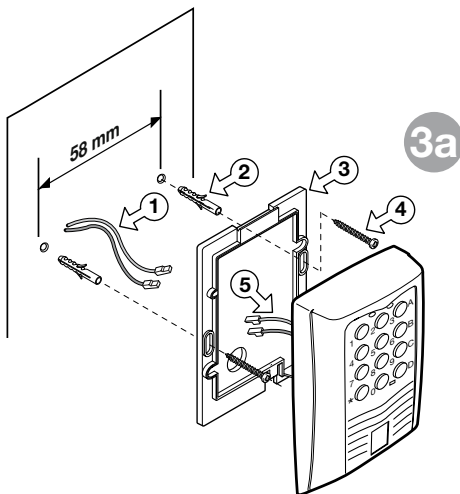

PROCEDURA DI PROGRAMMAZIONE



Prima di procedere alla prima memorizzazione dei codici, ricordarsi di cancellare interamente la memoria.

1. Cancellazione totale della memoria

1a Aprire il jumper "J2" sull'interfaccia

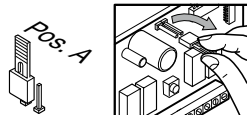

1b Premere il pulsante "P1" sull'interfaccia 4 volte in sequenza, e la quarta volta tenerlo premuto per 6 secondi.

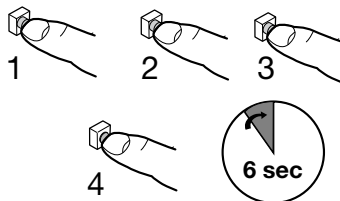

1c LED "L1" verde e "L2" rosso lampeggiano e restano accessi durante la cancellazione



1d LED rosso "L2" si spegne e LED verde "L1" lampeggia per qualche secondo poi si spegne



A questo punto tutti i codici sono stati cancellati!

2. Registrazione codice di accesso alle funzioni di programmazione in remoto da tastiera

2a Chiudere il jumper "J2" sull'interfaccia

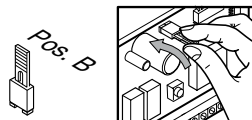



2b Premere il pulsante "P1" per almeno 6 secondi



2c Il LED rosso "L2" sull'interfaccia si accende.

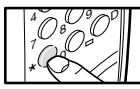

2d  Digitare sulla tastiera il codice numerico scelto per abilitare l'accesso alle funzioni (max 6 cifre Es. 1-2-3-4-5-6) e premere conferma "*" 

2e  Sull'interfaccia il LED verde "L1" lampeggia e il LED rosso "L2" si spegne.



La memorizzazione del codice di accesso è avvenuta!

3. Memorizzazione codici e selezione funzioni

3a  Aprire il jumper "J2" sull'interfaccia

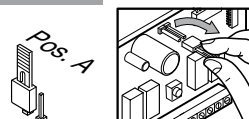

3b Premere il pulsante "P1" sull'interfaccia per almeno 3 secondi.

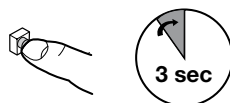

3c Il LED rosso "L2" sull'interfaccia si accende.

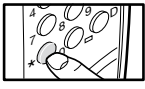

A questo punto la procedura di memorizzazione è attivata!

3d  Digitare sulla tastiera il codice numerico da memorizzare (max 6 cifre Es. 1-2-3-4-5-6) e premere conferma "*" 

3e La tastiera emette un **beep** per 2 secondi + LED verde acceso

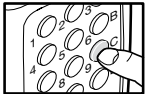

Il codice è stato accettato e memorizzato

3f Entro 13 secondi dalla conferma del codice premere una o più funzioni A-B-C-D in sequenza (Es. A-C) 

3g Premere conferma "*" e la tastiera emette un **beep** 

3h  Sull'interfaccia il LED verde "L1" lampeggia



Il codice è stato memorizzato. Le funzioni sono assegnate (Es. A-C).

MODALITÀ DI FUNZIONAMENTO







4. Memorizzazione codici da posizione remota

Se non è stata eseguita, in precedenza, la **"Registrazione codice di accesso programmazione in remoto"**, eseguire per intero la procedura (rif. 2, pag.5)



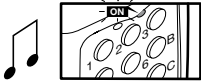

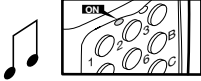

Attenzione! La memorizzazione sarà possibile solamente se il jumper sull'interfaccia **"J2"** è inserito

Se è stata eseguita la **"Registrazione codici di accesso programmazione in remoto"**:

- 4a**  Digitare sulla tastiera il codice di accesso alla memorizzazione e premere conferma **"★"** 
- 4b** La tastiera emette un **beep** ed i LED rosso e verde si accendono (poi il LED verde si spegne) 
- Funzione attiva!**
- 4c**  Digitare sulla tastiera il nuovo codice numerico da memorizzare (max 6 cifre Es. 1-2-3-4-5-6) e premere conferma **"★"** 
- 4d** La tastiera emette un **beep** per 2 secondi + LED verde acceso 
- Il codice è stato accettato e memorizzato**
- 4e** Entro 13 secondi dalla conferma del codice premere una o più funzioni A-B-C-D in sequenza (Es. **A-C**) 
- 4f** Premere conferma **"★"** e la tastiera emette un **beep** 
- Le funzioni sono assegnate (Es. A-C)**

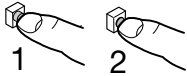
5. Cancellazione di un singolo codice

- 5a**  Aprire il jumper **"J2"** sull'interfaccia 
- 5b** Sull'interfaccia premere il pulsante **"P1"** 2 volte in sequenza e la seconda volta tenerlo premuto per 3 secondi  

5c Sull'interfaccia il LED verde "L1" e il LED rosso "L2" si accendono.



Dispositivo pronto per cancellare!

5d  Digitare il codice numerico da cancellare e premere conferma "*"



5e  Sull'interfaccia il LED verde "L1" lampeggia.

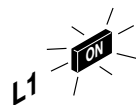

Codice cancellato!

6. Cancellazione di un singolo codice da posizione remota



Attenzione! La cancellazione sarà possibile solamente se il jumper sull'interfaccia "J2" è inserito

6a  Digitare sulla tastiera la seguente sequenza #*(codice da cancellare)*#
(ad esempio se si vuole cancellare il codice 112233, digitare #*112233*#)

6b La tastiera emette un beep per 2 secondi
+ LED verde e LED rosso accesi

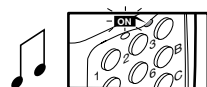

Il codice è stato cancellato!

7. Attivazione codice utente

7a  Digitare sulla tastiera il codice numerico utente e premere conferma "★"



7b La tastiera emette un **beep** per 2 secondi + LED verde acceso

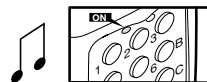

7c  Il LED verde "L1" si accende sull'interfaccia



Codice accettato!

7d  Premere A-B-C o D nella colonna a destra sulla tastiera (Es. "C")

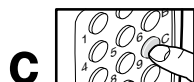

Attivazione avvenuta!

7e Dopo 5 secondi di inattività della tastiera, verrà emesso un **beep**. Il LED verde si spegne e si esce dalla modalità.

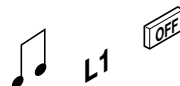

NOTE

- L'inserimento di un codice di più di 6 cifre annulla l'operazione in corso.
Tipo di segnalazione: la tastiera emette un **beep**.
- Il tempo a disposizione tra l'inserimento di una cifra e l'altra è di 5 secondi.
Trascorsi i secondi a disposizione l'operazione viene annullata.
- "Memorizzazione codici": memorizzato il codice si esce automaticamente dalla procedura dopo 20 sec.
Tipo di segnalazione: sulla tastiera LED rosso lampeggia, emissione di 6 **beep** in sequenza

Avvertenze

- Prima di procedere alla prima memorizzazione dei codici, cancellare interamente la memoria
- Si può registrare un solo codice di accesso alla memorizzazione in remoto.
Per cambiarlo è sufficiente ripetere la procedura e registrare il nuovo codice desiderato.
- La cancellazione totale della memoria azzerava anche il codice di accesso alla memorizzazione in remoto.
- Dopo 5 inserimenti consecutivi di un codice "errato" (non presente in memoria) il sistema va in blocco per 60 sec.
Tipo di segnalazione: la tastiera emette un **beep** e i due LED lampeggiano per 5 sec.
- Se premete il tasto # durante l'inserimento di un codice, tale codice verrà ignorato. Sarà necessario quindi reinserire il codice per intero.

Segnalazioni di errore

Interfaccia - LED rosso lampeggiante :

- memoria piena (tentativo di nuova memorizzazione fallito)
- codice esistente (in memorizzazione)
- codice inesistente (in cancellazione)

Tastiera - LED rosso lampeggiante

- accompagnato da tre **beep** lenti, codice esistente (in memorizzazione)
- codice inesistente (in cancellazione)
- accompagnato da tre **beep** veloci, codice errato in modalità di funzionamento.

Before commencing with the installation of this appliance make sure that you have read the following instructions carefully. In particular familiarise yourself with the safety devices required by the system, only then will you be able to use them to great effect. **Before beginning programming read the "NOTES" on page 19 carefully.** The use and installation of these appliances must rigorously respect the indications supplied by the manufacturer. The manufacturer accepts no liability for damage caused by, or situations arising from, the improper use of these appliances. These instructions are aimed at professionally qualified **"installers of electrical equipment"** and must respect the local standards and regulations in force.

Description

The system is made up of two elements connected together via cable:

- **DKS250T** outdoor numerical code keyboard,
- **DKS250R** serial connection interface, which also supplies the power supply to the keyboard.

The keyboard consists of an spray painted highly resistant anti-tamper metal case made in zama and chrome anti wear keys. Easy to install the keyboard has a protection grade of **IP57** and features an anti-tamper fastening system which can only be opened using a special tool.

It also has the following features:

- red signal LED
- green signal LED
- 10 numerical keys (0-9)
- one confirm key ★
- an operation cancel key #
- 4 channel functions (A, B, C, D)
- a signal buzzer.

The interface is housed in an indoor container **IP20** and can be connected to the keyboard using a two-wire telephone cable (or similar) **Ø 0,6 mm**, maximum length **150 m**. It is fitted with a programming button and two signal leds; **L1** green and **L2** red.

Use

The **DKS250** system allows the remote activation of electrical and electronic appliances via cable with its best use in the following areas: motorised gates and doors.

Number of user codes which can be stored (max 6 digits each).....	250
Number of available code combinations	1 million
Number of keyboards that can be connected in parallel to the interface.....	3

TECHNICAL SPECIFICATIONS

Interface power supply (DKS250R).....	12/24Vac-dc
Electrical input:	
Keyboard	6mA
Interface with keyboard.....	31mA
Interface with keyboard and one activated relay.....	54mA
Maximum commutable power at the relay with resistive load excluding light bulbs:	
load in ac/dc	60VA/24W
maximum voltage	30Vac-dc
maximum electrical input	1 A
relay activation delay time	80-100ms
Keyboard/interface operating temperature range	-10° ...+55°C

Overall dimensions

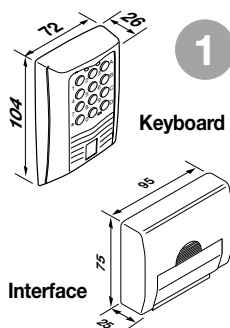

INTERFACE BOX INSTALLATION IP20

Depending on the type of installation, work out the position in which the programmer will be situated remembering that the site must be:

- indoors (or stored in a waterproof container if installed outdoors)
- a position safe from accidental collision;
- in a position which the technician can easily reach.

Fastening:

- To the wall, distance between centres **75 mm**, using two **M4** screws and relative rawlplugs (not supplied by us)
- In a waterproof container using the supplied double sided adhesive tape

Interface electrical connection



Warning! The receivers must only be powered by a safety power pack. The use of non safety power packs could provoke damage to the system.

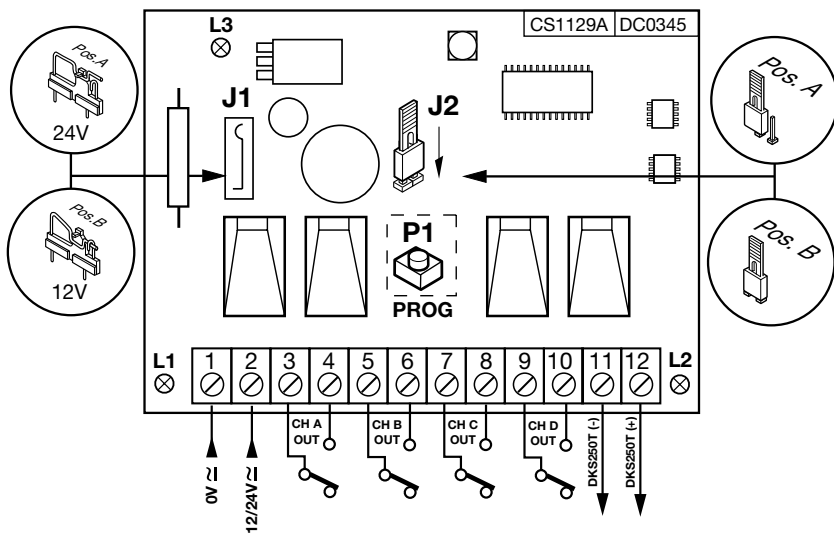

2

The interface (printed circuit CS1129A/B) is fitted with an indoor container and has a 12-way terminal board with the following electrical connection:

12V ac/dc between binding posts 1-2 with jumper "J1" in position "B"

24V ac/dc between binding posts 1-2 with jumper "J1" in position "A"

(L3 lights up to indicate that the appliance is receiving power)

The interface has four normally open relays which are marked CHA, CHB, CHC, and CHD.

- According to the distance between the interface and the keyboard run the cable carrying the power to the keyboard and the serial line data.
- Connect the Faston cables: **FS1** black to binding post "11"; **FS2** red to binding post "12" (fig. 3b)

INSTALL THE OUTDOOR KEYBOARD IP57

1) Pass the connecting cables, "1" coming from the interface, through the wall.

2) Drill the wall at the distance indicated in figure 3a (58 mm).

3) Insert the rawplugs "2" supplied with the kit.

4) Fasten down the counter plate "3" using the screws "4" supplied with the kit.

5) Connect the Fastons on the wires "1" to the Fastons on the keyboard "5" (fig. 3a-3b):

- the **red wire** of the keyboard connects to binding post **12** on the interface card
- the **black wire** of the keyboard connects to binding post **11** on the interface card

6) Position the keyboard (fig. 3b-3c) and fasten it down to the counter plate using the special screw "S1" and the tool "K1".

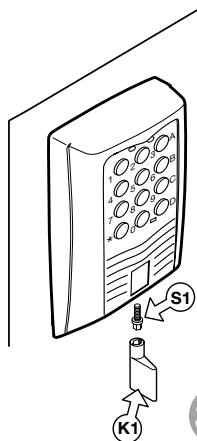
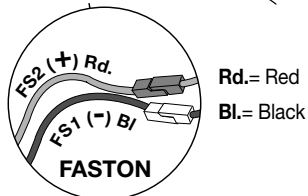
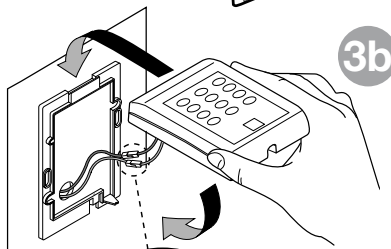
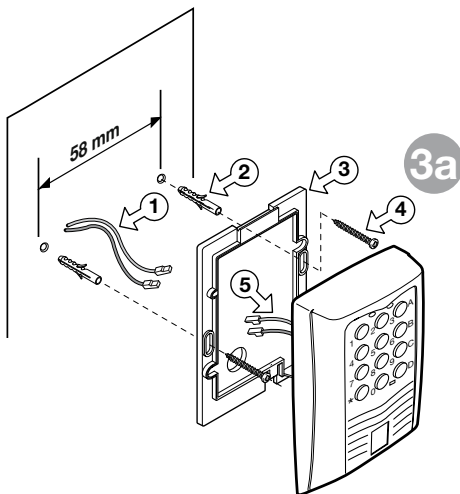

PROGRAMMING PROCEDURE



Attention! Before memorising the transmitters for the first time remember to cancel the entire memory content.

1. Cancelling the entire memory content

1a Remove jumper "J2" from the interface

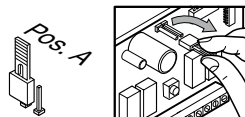

1b Press button "P1" 4 times in sequence on the interface and the fourth time hold it down for 6 seconds.

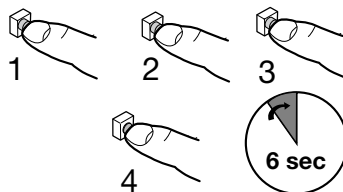

1c The green LED "L1" and the red LED "L2" will flash and remain lit during cancelling



1d The red LED "L2" switches off and the green LED "L1" will flash for a few seconds then it too will switch off



At this point all codes have been cancelled!

2. Memorising the programming function access code for remote memorisation from the keyboard

2a Insert jumper "J2" on the interface

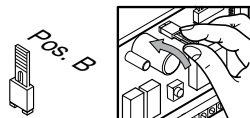

2b Press button "P1" for at least six seconds





2c Red LED "L2" on the interface will flash

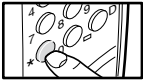

2d Type the chosen access code into the keyboard to enable the functions (max 6 digits e.g. 1-2-3-4-5-6) and press confirm "*" 

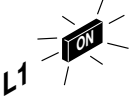
*

2e The green LED "L1" will flash and the red LED "L2" will switch off on the interface.  

The access code has been memorised!

3. Storing codes and selecting functions

3a Remove jumper "J2" from the interface 

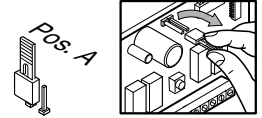

3b Press button "P1" on the interface for at least three seconds 

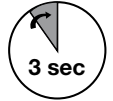

3c The red LED "L2" will flash on the interface 

At this point the memorising procedure is active!

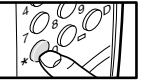
3d Type the numerical code to be stored into the keyboard (max 6 digits e.g. 1-2-3-4-5-6) and press confirm "*" 

*

3e The keyboard will emit one **beep** for two seconds and the green LED will light up 

The code has been accepted and stored

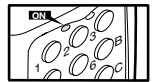

3f Within 13 seconds of confirming the code press one or more functions A-B-C-D in sequence (e.g. A-C) 

3g Press confirm "*" and the key board will emit a **beep** 

*

3h The green LED "L1" will flash on the interface 

The code has been memorised and the functions have been assigned (e.g. A-C).

OPERATING MODE









4. Memorising codes from a remote position

If you have not already carried out the "**Memorising the programming function access code for remote memorisation from the keyboard**", do so now (ref. 2, pag. 14)

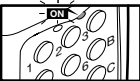



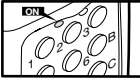
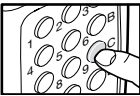

Attention! Memorising is only possible if jumper "J2" on the interface has been inserted

If the "**Memorising the programming function access code**" procedure has been carried out:

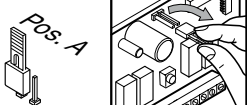
- 4a  Type the function access code into the keyboard and press confirm "*****" 
- 4b  The keyboard will emit a **beep** and the **red** and **green** LEDs will light up (the green LED will then switch off) 
The function is active!
- 4c  Type the desired numerical code into the keyboard (max 6 digits e.g. 1-2-3-4-5-6) and press confirm "*****" 
- 4d  The keyboard will emit a **beep** for two seconds and the green LED will light up 
The code has been accepted and memorised
- 4e  Within 13 seconds of confirming the code press one or more functions A-B-C-D in sequence (e.g. **A-C**)
- 4f  Press confirm "*****" and the keyboard will emit a **beep** 
The functions have been assigned (e.g.. A-C)

5. Cancelling a single code

- 5a  Remove jumper "**J2**" from the interface 
- 5b  Press button "**P1**" 2 times in sequence on the interface and the second time hold it down for 3 seconds.  

5c The green LED "L1" and the red LED "L2" will light up on the interface.



The device is ready to cancel!

5d  Type in the numerical code to be cancelled and press confirm "*"



5e  The green LED "L1" will flash on the interface.

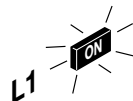

The code has been cancelled!

6. Cancelling a single code from a remote position



Attention! Memorising is only possible if jumper "J2" on the interface has been inserted

6a  Type the following sequence into the keyboard #*(code to cancel)*# (for example if you want to cancel 112233, type in #*112233*#)

6b The keyboard will emit a **beep** for two seconds the green LED and red LED will light up

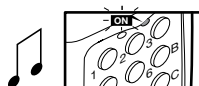

The code has been cancelled!

7. Activating a user code

7a



Type in the numerical user code on the keyboard and press confirm "*"

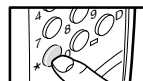

7b

The keyboard will emit a **beep** for 2 seconds and the green LED will light up.

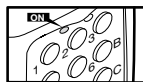

7c



The green LED "L1" will light up on the interface



The code has been accepted!

7d



Press A-B-C or D in the right-hand column of the keyboard (e.g. "C")

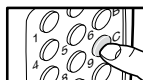

Activation has been carried out!

7e

After 5 seconds of keyboard inactivity a **beep** will sound.
The green LED will switch off and you will quit the user code mode.

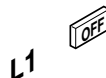

NOTES

- Inserting a code with more than 6 digits will cancel the operation in progress.
Signal: the keyboard will emit a **beep**.
- The available time between inserting one digit and the next is 5 seconds.
Once the time has expired the operation will be cancelled.
- "Code memorisation": once the code has been memorised the device will automatically quit the procedure after 20 seconds has elapsed.
Signal: the red LED will flash on the keyboard and 6 consecutive **beeps** will sound

Warnings

- Before memorising the transmitters for the first time remember to cancel the entire memory content.
- Only one remote code memorising access code can be stored.
To change it you need only repeat the procedure and save the new code.
- Cancelling the entire memory content will also cancel the remote code memorising access code.
- After 5 attempts to insert and incorrect code (doesn't exist in memory) the system will remain blocked for 60 seconds.
Signal: the keyboard will sound 1 **beep** and both LEDs will flash for 5 seconds.
- If you press the # key while inserting a code that code will be ignored. You will then have to reinsert the code again.

Error signals

Interface - the red LED flashes:

- memory full (attempt to memorise has failed)
- code doesn't exist (during memorisation)
- code doesn't exist (during cancellation)

Keyboard - the red LED flashes:

- together with three slow **beeps**, code doesn't exist (during memorisation)
- code doesn't exist (during cancellation)
- together with three fast **beeps**, code doesn't exist in the operating mode.

Avant de procéder à l'installation, lire attentivement ce livret. En particulier, se familiariser avec les dispositifs de sécurité prévus sur le produit afin de pouvoir les utiliser au mieux. **Avant d'engager la programmation, lire attentivement les "NOTES" à la page 28.** Une diverse utilisation des produits ou leur destination à un usage différent de ceux prévus et/ou conseillés n'a pas été expérimentée par le fabricant. Par conséquent, les travaux effectués sont entièrement sous la responsabilité de l'installateur. Ce livret est destiné à des personnes titulaires d'un certificat d'aptitude professionnelle pour l'installation des "appareils électriques" et requiert une bonne connaissance de la technique appliquée professionnellement. Le Constructeur décline toute responsabilité pour les éventuels dommages entraînés par la non observation des normes de sécurité en vigueur actuellement durant l'installation des appareils.

Descriptif

Le système se compose de deux éléments, l'un branché à l'autre au moyen d'un câble:

- **DKS250T** clavier numérique pour l'extérieur,
- **DKS250R** interface pour le branchement sériel se chargeant également de l'alimentation du clavier.

Le **clavier** est constitué d'une structure métallique antivandale en zamac, peinture haute résistance, et touches chromées résistant à l'usure. Facile à poser, il bénéficie d'un indice de protection **IP57** et d'un système de fixation antivandale avec vis et clé spéciales.

Il est doté de:

- LED rouge de signalisation
- LED verte de signalisation
- 10 touches numériques (0-9)
- une touche de confirmation **★**
- une touche d'annulation de l'opération **#**
- 4 fonctions de canal (A, B, C, D)
- avertisseur sonore.

L'**interface**, logée sous boîtier pour l'intérieur **IP20**, se raccorde au clavier à travers un câble téléphonique (ou similaire) à deux conducteurs de **Ø 0,6 mm**, d'une longueur maximum de **150 m**, et est dotée d'une touche de programmation, et de deux leds, verte **L1** et rouge **L2**, pour la signalisation visuelle.

Domaine d'application

Le système **DKS250** permet l'actionnement, à travers câble, d'appareils électriques et électroniques, en toute sécurité. Il est particulièrement indiqué pour la commande de portes motorisées.

Nombre de codes usager mémorisables (chacun de 6 chiffres maxi.)..... 250

Nombre de combinaisons de codes..... 1 million

Number of keyboards that can be connected in parallel to the interface..... 3

CARACTÉRISTIQUES TECHNIQUES

Alimentation interface DKS250R.....	12/24 Vac-dc
Intensité absorbée:	
Clavier	6 mA
Interface avec clavier	31 mA
Interface avec clavier et un relais excité	54 mA
Puissance maxi. commutable par le relais avec charge résistive (ampoules exclues):	
Charge en ac/dc.....	60VA/24W
Tension maximum	30Vac-dc
Courant maxi	1 A
Retard à l'activation du relais.....	80-100ms
Température de fonctionnement clavier/interface	-10° ...+55°C

Dimensions d'encombrement

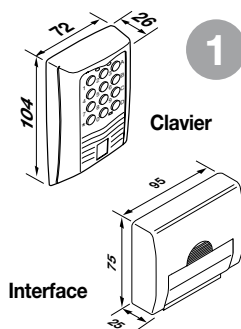

MISE EN PLACE DE L'INTERFACE SOUS BOÎTIER IP20

En fonction de la particularité de l'installation, déterminer l'endroit d'implantation du système.
L'interface devra être placée:

- à l'intérieur (dans un boîtier étanche, s'il est prévu de l'installer à l'extérieur),
- à l'abri de chocs et d'actes de vandalisme;
- à un endroit aisément accessible par le technicien chargé de la maintenance.

Fixation

- Au mur, entraxe **75 mm**, au moyen de deux vis **M4** et chevilles Fischers (hors fourniture).
- Sous boîtier étanche, en utilisant l'adhésif fourni en standard.

Branchement électrique de l'interface



Attention! Alimenter l'interface en utilisant exclusivement un alimentateur de sécurité. Le non-respect de cette consigne peut comporter des risques.

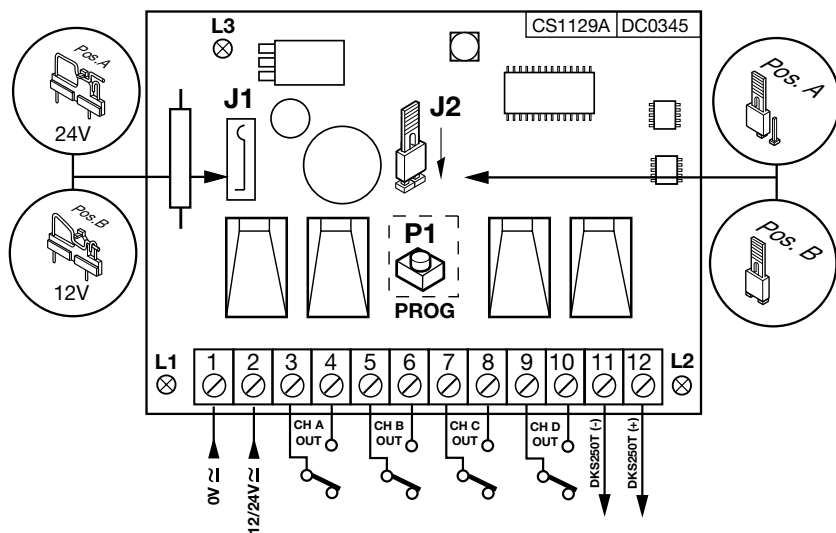

2

L'interface (circuit imprimé CS1129A/B) est équipée d'un boîtier, adapté à une pose en environnement interne, et d'un bornier à 12 voies avec branchement électrique:

12V ac/dc entre les bornes 1-2 avec cavalier "J1" en position "B",

24V ac/dc entre les bornes 1-2 avec cavalier "J1" en position "A".

(L3 s'allume quand l'appareil est sous tension)

L'interface dispose de quatre relais dont les sorties sont marquées respectivement de CHA, CHB, CHC et CHC (seulement contact N.O.).

- En fonction de la distance entre l'interface et le clavier, prévoir le câble de branchement qui alimente le clavier à code, à travers lequel s'effectuera la communication série des données.
- Brancher les fils des cosses faston: **FS1** noir à la borne "11"; **FS2** rouge à la borne "12" (fig. 3b).

MISE EN PLACE DU CLAVIER POUR L'EXTÉRIEUR IP57

1) Faire passer les fils de branchement "1", qui proviennent de l'interface, à travers le mur.

2) Perforer le mur en respectant la distance indiquée sur la figure 3a (58 mm).

3) Introduire les chevilles (fischer) "2" fournies avec le kit.

4) Fixer la contreplaque "3" au moyen des vis "4" fournies avec le kit.

5) Brancher les cosses faston des fils "1" aux cosses faston du clavier "5" (fig. 3a-3b):
 - **fil rouge** du clavier à la borne 12 de l'interface,
 - **fil noir** du clavier à la borne 11 de l'interface

6) Après quoi, positionner le clavier (fig. 3b-3c) et le fixer à la contreplaque au moyen de la vis spéciale "S1" et de l'outil "K1" expressément prévu à cet effet

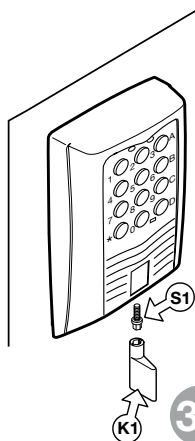
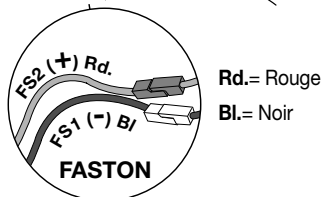
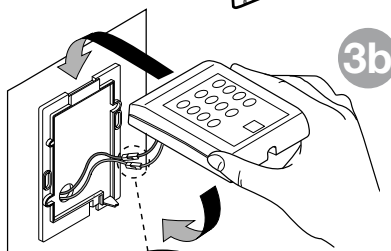
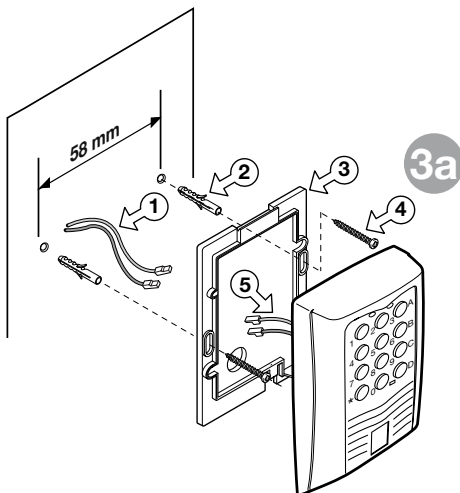

PROCÉDÉ DE PROGRAMMATION



Attention! Avant d'effectuer la première mémorisation de codes, se rappeler d'effacer entièrement la mémoire.

1. Effacement total de la mémoire

1a Ouvrir le cavalier "J2" sur l'interface

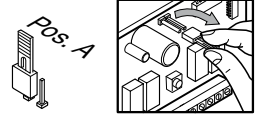

1b Appuyer 4 fois de suite le bouton "P1" sur l'interface et le maintenir appuyé pendant 6 secondes à la quatrième pression.

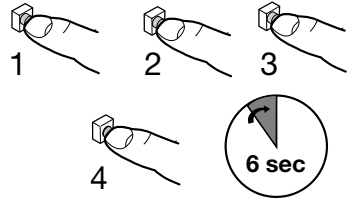

1c Les LEDS, "L1" verte et "L2" rouge, clignotent et restent allumées pendant l'effacement

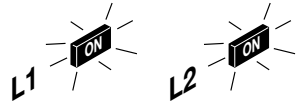

1d Le LED rouge "L2" s'éteint, tandis que la LED verte "L1" clignote pendant quelques instants avant de s'éteindre à son tour



À ce point, tous les codes ont été effacés!

2. Mémorisation du code d'accès aux fonctions de programmation à distance du clavier

2a Fermer le cavalier "J2" sur l'interface.

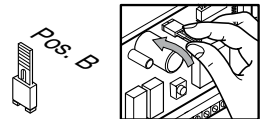

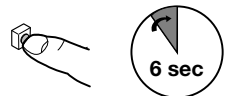

2b Appuyer sur le bouton "P1" pendant au moins 6 secondes



2c La LED rouge "L2" sur l'interface s'allume.

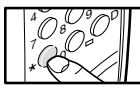

2d  Taper sur le clavier le code numérique d'accès aux fonctions (maxi. 6 chiffres, ex. 1-2-3-4-5-6), et appuyer sur confirmation "★".  *

2e  Sur l'interface, la LED verte "L1" clignote et la LED rouge "L2" s'éteint.



La mémorisation du code d'accès a eu lieu!

3. Mémorisation des codes et sélection des fonctions

3a  Ouvrir le cavalier "J2" sur l'interface

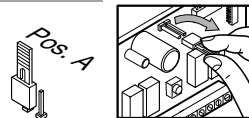

3b Appuyer sur le bouton "P1" sur l'interface pendant au moins 3 secondes



3c La LED rouge "L2" sur l'interface s'allume.



À ce point, le procédé de mémorisation est activé!

3d  Taper sur le clavier le code numérique à mémoriser (maxi. 6 chiffres, ex. 1-2-3-4-5-6), et appuyer sur confirmation "★"



3e Le clavier émet un **bip** pendant 2 secondes + LED verte allumée.

Le code a été accepté et mémorisé

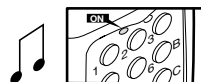

3f Dans les 13 secondes qui suivent la confirmation du code, appuyer sur une ou plusieurs fonctions A-B-C-D en respectant la séquence (Ex. **A-C**)

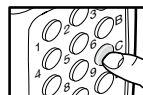

3g Appuyer sur confirmation "★"; le clavier émet un **bip**

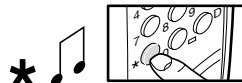

3h  Sur l'interface, la LED verte "L1" clignote



Le code a été mémorisé, et les fonctions assignées (Ex. A-C).

MODE DE FONCTIONNEMENT



4. Mémorisation des codes à distance

Si la "**Mémorisation du code d'accès à la programmation à distance**" n'a pas été effectuée précédemment, exécuter tout le procédé (réf. 2, page 23)



Attention! La mémorisation sera possible seulement si le cavalier "**J2**" sur l'interface a été connecté

Si la "**Mémorisation du code d'accès à la programmation à distance**" a été effectuée:

4a  Taper sur le clavier le code d'accès à la mémorisation, et appuyer sur confirmation "*****" 

4b Le clavier émet un **bip**, et les LEDS **rouge** et **verte** s'allument (ensuite, la LED verte s'éteint)

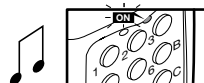

La fonction est activée!

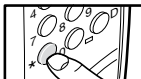
4c  Taper sur le clavier le nouveau code numérique à mémoriser (maxi. 6 chiffres, ex. 1-2-3-4-5-6), et appuyer sur confirmation "*****" 

4d Le clavier émet un **bip** pendant 2 secondes + LED verte allumée.

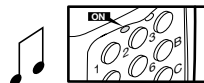

Le code a été accepté et mémorisé

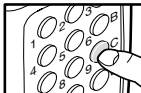
4e Dans les 13 secondes qui suivent la confirmation du code, appuyer sur une ou plusieurs fonctions A-B-C-D en respectant la séquence (Ex. **A-C**) 

4f Appuyer sur confirmation "*****"; le clavier émet un **bip**



Les fonctions ont été assignées (Ex. A-C)

5. Effacement d'un code

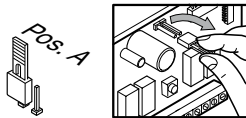
5a  Ouvrir le cavalier "**J2**" sur l'interface 

5b Sur l'interface, appuyer deux fois de suite le bouton "**P1**" et le maintenir appuyé pendant 3 secondes à la deuxième pression.



5c Sur l'interface, les LEDS verte "L1" et rouge "L2" s'allument.



Le dispositif est prêt à effacer!

5d  Taper le code numérique à effacer, et appuyer sur confirmation "*"

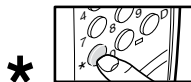

5e  Sur l'interface, la LED verte "L1" clignote.

Le code a été effacé!



6. Effacement d'un code à distance



Attention! L'effacement n'est faisable que si le cavalier "J2" est connecté.

6a  Taper sur le clavier la séquence suivante #*(code à effacer)*#
(par exemple, pour effacer le code 112233, taper #*112233*#)

6b Le clavier émet un **bip** pendant 2 secondes
+ LED verte et LED rouge allumées.

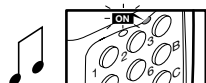

Le code a été effacé!

7. Activation du code usager

- 7a**  Taper sur le clavier le code numérique de l'utilisateur, et appuyer sur confirmation "*"

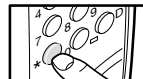

- 7b** Le clavier émet un **bip** pendant 2 secondes + LED verte allumée

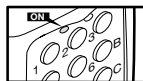

- 7c**  La LED "L1" s'allume sur l'interface



Code accepté!

- 7d**  Appuyer sur A-B-C ou D dans la colonne à droite sur le clavier (Ex. "C")

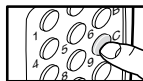

Activation exécutée!

- 7e** Après 5 secondes sans qu'une touche du clavier ait été appuyée, un **bip** retentit, la LED verte s'éteint, et on quitte la programmation.



NOTES

- L'introduction d'un code composé de plus de 6 chiffres annule l'opération en cours.
Type de signalisation: le clavier émet un **bip**.
- Le temps à disposition entre une introduction de code et la successive est de 5 secondes.
Une fois que ce laps de temps s'est écoulé, l'opération s'annule.
- "Mémorisation de codes ": 20 sec. après que le code ait été mémorisé, on quitte automatiquement le procédé.
Type de signalisation: sur le clavier, la LED rouge clignote, et une série de **6 bips** se déclenche.

Remarque

- Avant de procéder à la première mémorisation de codes, effacer toute la mémoire.
- Il est possible de mémoriser un seul code d'accès à la mémorisation à distance.
Pour le modifier, il suffit de répéter le procédé et de mémoriser le nouveau code.
- L'effacement total de la mémoire annule également le code d'accès à la mémorisation à distance.
- Si l'on introduit 5 fois de suite un code erroné (qui n'existe pas en mémoire), le système se bloque pendant 60 sec.
Type de signalisation: le clavier émet un **bip**, et les deux leds clignent pendant 5 sec.
- En cas de pression sur la touche # pendant l'entrée d'un code, celui-ci sera ignoré. Dans ce cas, il faudra entrer une autre fois tout le code.

Signalisations d'erreur

Interface – LED rouge clignotante:

- mémoire saturée
- code existant (en mémoire)
- code inexistant (en phase d'effacement)

Clavier - LED rouge clignotante:

- accompagnée de trois **bips** lents, code existant (en mémoire)
- code inexistant (en phase d'effacement)
- accompagnée de trois **bips** rapides, code erroné durant le fonctionnement.

Bevor mit der Installation begonnen wird, sollte das vorliegende Heft aufmerksam gelesen werden. Insbesondere sollten die vom Produkt vorgesehenen Sicherheitseinrichtungen zwecks bester Effizienz in Augenschein genommen werden. **Bevor mit der Programmierung begonnen wird, sollten aufmerksam die "ANMERKUNGEN" auf Seite 37 gelesen werden.** Die Anwendung und Nutzung der Produkte zu einem anderen Zweck, als es vorgesehen und/oder geraten wurde, ist nicht vom Hersteller erprobt worden. Die Installationsarbeiten erfolgen daher unter der vollständigen Verantwortung des Installateurs. Das vorliegende Handbuch wendet sich an Personen, die zur Installation von "**Elektrogeräten**" befähigt sind und setzt gute technische Kenntnisse voraus. Der Hersteller lehnt jegliche Verantwortung für eventuelle Schäden ab, die durch die fehlende Beachtung der zur Zeit geltenden Sicherheitsnormen bei der Installation entstanden sind.

Beschreibung

Das System besteht aus zwei durch ein Kabel miteinander verbundenen Elementen:

- **DKS250T** numerische Tastatur für die Aussenanwendung,
- **DKS250R** Schnittstelle für den seriellen Anschluss, dient auch zur Stromversorgung der Tastatur.

Die Tastatur hat eine einbruchssichere, mit hochwiderstandsfähigem Lack lackierte Metallstruktur aus Zamak und ist mit verschleissfesten, chromierten Tasten ausgestattet. Sie ist leicht zu installieren, hat den Schutzgrad **IP57** und verfügt über ein einbruchssicheres Befestigungssystem mit Spezialschrauben und -schlüssel.

Sie verfügt desweiteren über:

- rotes Signalisierungs-LED
- grünes Signalisierungs-LED
- 10 numerische Tasten (0-9)
- eine Bestätigungstaste *****
- eine Taste zur Verfahrensannullierung **#**
- 4 Kanalfunktionen (A, B, C, D)
- Summer zur akustischen Meldung.

Die in einem Gehäuse **IP20** zur Innenanwendung untergebrachte **Schnittstelle** wird mit einem zweiadrigen **Ø 0,6 mm**, maximal **150 m** langem Telefonkabel (oder dergleichen) an die Tastatur angeschlossen. Sie verfügt über eine Programmierstaste und zwei Signalisierungs-LED: **L1** grün und **L2** rot.

Anwendungsmöglichkeiten

Das System **DKS250** ermöglicht mittels Kabelverbindung die vollkommen gesicherte Betätigung von elektrischen und elektronischen Apparaturen und findet seine beste Anwendung in der Steuerung von motorisierten Türen und Toren.

Anzahl der speicherbaren Benutzercodes (jeweils max. 6 Ziffern): 250

Anzahl der Codekombinationsmöglichkeiten: 1 Million

Anzahl an Tastaturen, die parallel an eine Schnittstelle angeschlossen werden können..... 3

TECHNISCHE DATEN

Stromversorgung Schnittstelle DKS250R..... 12/24Vac-dc

Stromaufnahme:

Tastatur 6mA

Schnittstelle mit Tastatur 31mA

Schnittstelle mit Tastatur und einem aktiven Relais 54mA

Höchste umschaltbare Leistung vom Relais mit ohmscher Belastung (ohne Glühbirnen):

Last bei ac/dc..... 60VA/24W

Höchstspannung 30Vac-dc

Größte Stromstärke..... 1 A

Verzögerung bei der Aktivierung des Relais 80-100ms

Betriebstemperatur Tastatur/Schnittstelle -10° ...+55°C

Aussenabmessungen

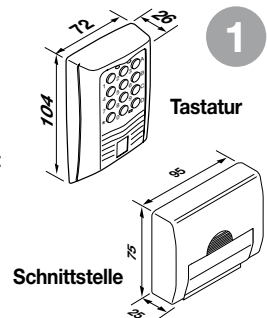

INSTALLATION SCHNITTSTELLE MIT GEHÄUSE IP20

An Hand der Typologie und Eigenschaften der Anlage die Einbaustelle des Systems bestimmen.
Die Schnittstelle muss untergebracht werden:

- In Innenräumen (in wasserdichtem Gehäuse bei Außeninstallationen).
- Geschützt vor Stößen und mutmaßlichen Eingriffen.
- An einer für den Techniker zwecks Wartung leicht zugänglichen Stelle.

Befestigung:

- An der Mauer mittels zwei Schrauben **M4** und passenden Fischer-Dübeln (werden nicht mitgeliefert), Bohrungsabstand **75 mm**.
- Im wasserdichten Gehäuse durch Verwendung eines serienmäßig mitgelieferten doppelseitigen Klebebandes.

Elektrischer Anschluss der Schnittstelle



Achtung! Zur Versorgung der Schnittstelle ausschließlich ein Sicherheitspeisegerät verwenden. Die Verwendung eines andersartigen Speisegerätes kann gefährlich sein.

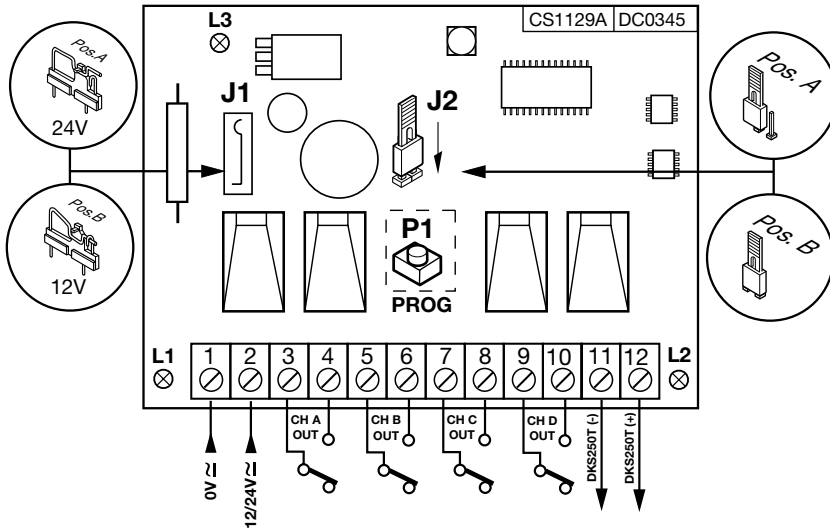

Schnittstelle (gedruckter Schaltkreis CS1129A/B) mit Gehäuse für Innenräume und 12-Wege-Anschlussklemmleiste mit Stromanschluss:

12V ac/dc zwischen den Klemmen 1-2 mit Jumper "J1" in Stellung "B",

24V ac/dc zwischen den Klemmen 1-2 mit Jumper "J1" in Stellung "A".

(L3 beleuchtet wenn das Gerät eingeschaltet ist)

Die Schnittstelle verfügt über vier Relais, deren Ausgänge entsprechend mit CHA, CHB, CHC, und CHD (nur Einschaltgliedkontakt) gekennzeichnet sind.

- Das Anschlusskabel, mit dem die serielle Datenübertragung erfolgt und das die Code-Tastatur mit Strom versorgt, entsprechend dem Abstand zwischen der Schnittstelle und der Tastatur verlegen.
- Die Kabel der Fastons anschließen: **FS1** schwarze an die Anschlussklemme "11"; **FS2** rot an die Anschlussklemme "12" (abb. 3b).

INSTALLATION TASTATUR FÜR AUSSENANWENDUNG IP57

- 1) Die von der Schnittstelle kommenden Anschlusskabel "1" durch die Mauer führen.

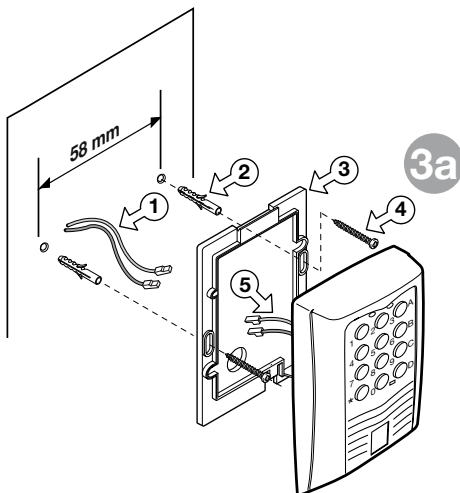

- 2) Die Mauer in dem wie in der Abbildung 3a angezeigten Abstand (58 mm) anbohren.

- 3) Die mit dem Bausatz mitgelieferten Fischer-Dübel "2" einstecken.

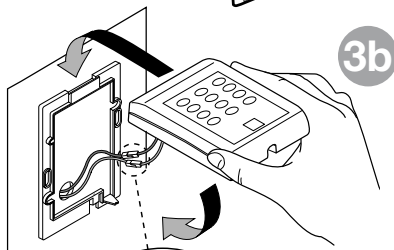

- 4) Die Befestigungsplatte "3" mit den im Bausatz mitgelieferten Schrauben "4" befestigen.

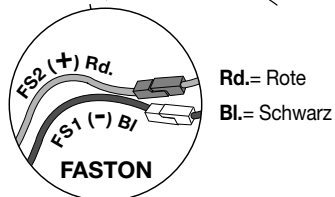

- 5) Die Fastons der Kabel "1" mit den Fastons der Tastatur "5" (Abb. 3a-3b) verbinden:

- rote Leitung von der Tastatur an die Anschlussklemme 12 der Schnittstelle
- schwarze Leitung von der Tastatur an die Anschlussklemme 11 der Schnittstelle

- 6) Nun die Tastatur positionieren (Abb. 3b-3c) und mit der Spezialschraube "S1" unter Verwendung des dafür vorgesehenen Werkzeuges "K1" an der Befestigungsplatte befestigen.

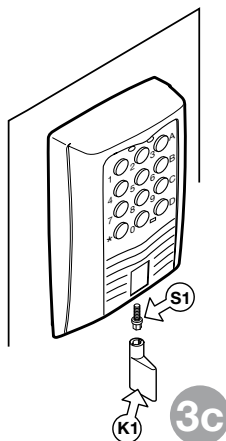

PROGRAMMIERVERFAHRUNG



Bevor mit der erstmaligen Speicherung der Codes begonnen wird, muss der Speicher zuerst vollkommen gelöscht werden.

1. Komplette Löschung des Code-Speichers

1a Auf der Schnittstelle den Jumper "J2" öffnen

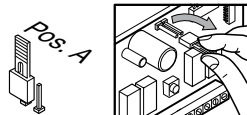

1b Die Taste "P" auf der Schnittstelle 4-mal nacheinander drücken und beim 4-ten Mal für 6 Sekunden gedrückt halten.

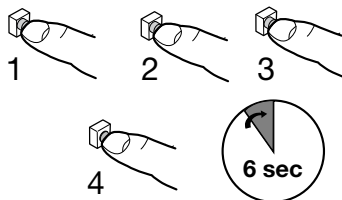

1c Die grüne LED "L1" und rote "L2" blinken und leuchten dann während der Löschung



1d Die rote LED "L2" erlischt und die grüne LED "L1" blinkt einige Sekunden lang und erlischt dann ebenfalls



Jetzt sind alle Codes gelöscht worden!

2. Registrierung des Freigabecodes für die Funktionen der von der Tastatur ausgeführten Fernprogrammierung

2a Auf der Schnittstelle den Jumper "J2" schließen

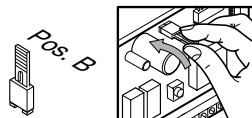





2b Die Taste "P1" drücken und mindestens 6 Sekunden lang gedrückt halten

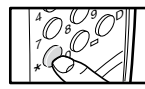

2c Die rote LED "L2" leuchtet auf der Schnittstelle auf.



2d  Auf der Tastatur den für die Freigabe des Zugriffs auf die Funktionen ausgewählten numerischen Code eingeben (max. 6 Ziffern z.B. 1-2-3-4-5-6) und zur Bestätigung "*" drücken.  *

2e  Auf der Schnittstelle blinkt die grüne LED "L1" und erlischt die rote LED "L2".  L1  L2

Der Freigabecode ist gespeichert worden!

3. Codespeicherung und Funktionenwahl

3a  Auf der Schnittstelle den Jumper "J2" öffnen  

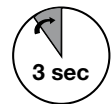
3b Die Taste "P1" auf der Schnittstelle drücken und mindestens 3 Sekunden lang gedrückt halten.  

3c Die rote LED "L2" leuchtet auf der Schnittstelle auf.  L2

Jetzt ist das Speicherverfahren aktiviert!

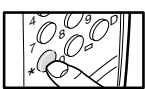

3d  Auf der Tastatur den zu speichernden numerischen Code eingeben (max. 6 Ziffern z.B. 1-2-3-4-5-6) und zur Bestätigung "*" drücken.  *

3e Die Tastatur gibt 2 Sekunden lang einen **Beep-Ton** von sich und die grüne LED leuchtet auf  

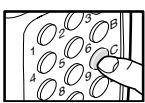
Der Code wurde akzeptiert und gespeichert!

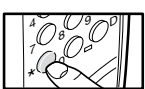
3f Innerhalb von 13 Sekunden nach der Bestätigung des Codes eine oder mehrere Funktionen A-B-C-D nacheinander drücken (z.B. A-C). 

3g Die Bestätigungstaste "*" drücken und die Tastatur gibt einen **Beep-Ton** von sich.  

3h  Auf der Schnittstelle blinkt die grüne LED "L1".  L1

Der Code ist gespeichert worden. Die Funktionen wurden zugeordnet (z.B. A-C).

BETRIEBSWEISE









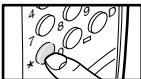

4. Speicherung der Codes von einer entfernten Stelle aus

Wenn die **Registrierung des Zugriffscodes für die ferngesteuerte Programmierung** zuvor noch nicht ausgeführt worden ist, muss das Verfahren vollständig ausgeführt werden (Absatz 2, S. 32)



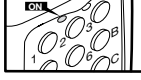



Achtung! Die Speicherung ist nur dann möglich, wenn der Jumper **"J2"** auf der Schnittstelle eingesetzt ist.

Wenn die Registrierung des Freigabecodes für die Fernprogrammierung ausgeführt worden ist:

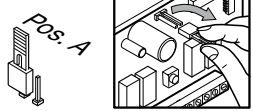
- 4a**  Auf der Tastatur den Freigabecode für die Speicherung eingeben und die Bestätigungstaste **"★"** drücken 
- 4b** Die Tastatur gibt einen **Beep-Ton** von sich und die **rote** und **grüne** LED leuchten auf (die grüne LED erlischt dann)  
- Funktion aktiviert!**
- 4c**  Auf der Tastatur den neuen zu speichernden numerischen Code eingeben (max. 6 Ziffern z.B. 1-2-3-4-5-6) und die Bestätigungstaste **"★"** drücken 
- 4d** Die Tastatur gibt 2 Sekunden lang einen **Beep-Ton** von sich und die grüne LED leuchtet auf.  
- Der Code wurde akzeptiert und gespeichert**
- 4e** Innerhalb von 13 Sekunden nach der Bestätigung des Codes eine oder mehrere Funktionen A-B-C-D nacheinander drücken (z.B. **A-C**) 
- 4f** Die Bestätigungstaste **"★"** drücken und die Tastatur gibt einen **Beep-Ton** von sich  
- Die Funktionen wurden zugeordnet** (z.B. **A-C**)

5. Löschung eines einzelnen Codes

- 5a**  Auf der Schnittstelle den Jumper **"J2"** öffnen 
- 5b** Die Taste **"P"** auf der Schnittstelle 2-mal nacheinander drücken und beim 2-ten Mal für 3 Sekunden gedrückt halten.   

5c Auf der Schnittstelle leuchten die grüne LED "L1" und die rote LED "L2" auf.



Die Vorrichtung ist für die Löschung bereit!

5d Den zu löschenden numerischen Code eingeben und die Bestätigungstaste "*" drücken.



5e Auf der Schnittstelle blinkt die grüne LED "L1".



Code gelöscht!



6. Löschung eines einzelnen Codes von einer entfernten Stelle aus



Achtung! Die Löschung ist nur möglich, wenn der Jumper "J2" eingesetzt wurde.

6a Auf der Tastatur die nachstehende Zeichenfolge **#*(zu löschender Code)*#** eingeben (zum Beispiel: Wenn der Code 112233 gelöscht werden soll, **#*112233*#** eingeben)



6b Die Tastatur gibt 2 Sekunden lang einen **Beep-Ton** von sich und die grüne und rote LED leuchten auf.

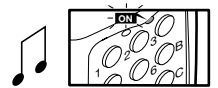

Code gelöscht!

7. Aktivierung des Benutzer-Codes



- 7a Auf der Tastatur den numerischen Benutzer-Code eingeben und die Bestätigungstaste "*" drücken

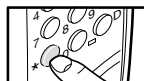

- 7b Die Tastatur gibt 2 Sekunden lang einen **Beep-Ton** von sich und die grüne LED leuchtet auf

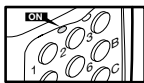

- 7c Die grüne LED "L1" leuchtet auf der Schnittstelle auf



Code akzeptiert!

- 7d A-B-C oder D rechts auf der Tastatur drücken (z.B. "C").

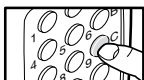

Aktivierung ausgeführt!

- 7e Nach einer Inaktivität der Tastatur von 5 Sekunden wird ein **Beep-Ton** abgegeben.
Die grüne LED erlischt und es erfolgt der Austritt aus der Modalität.

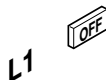

ANMERKUNGEN

- Die Eingabe eines Codes mit mehr als 6 Ziffern annulliert das laufende Verfahren.
Signalisierungsart: Die Tastatur gibt einen **Beep**-Ton von sich.
- Die zur Verfügung stehende Zeit zwischen der Eingabe der einzelnen Ziffern beträgt 5 Sekunden.
Nach Ablauf der zur Verfügung stehenden Sekunden wird das Verfahren annulliert.
- "Speicherung der Codes": Nach der Speicherung des Codes erfolgt nach 20 Sekunden automatisch der Austritt aus dem Verfahren.
Signalisierungsart: Auf der Tastatur blinkt die rote LED und es werden 6 **Beep**-Töne nacheinander abgegeben.

Hinweise

- Bevor mit der erstmaligen Speicherung der Codes begonnen wird, muss der Speicher zuerst vollkommen gelöscht werden.
- Es kann nur ein einziger Freigabecode für die Fernspeicherung registriert werden.
Zu dessen Änderung braucht nur das Verfahren wiederholt und der neue Code registriert zu werden.
- Die vollständige Löschung des Speichers löscht auch den Freigabecode für die Fernspeicherung.
- Nachdem 5mal nacheinander ein "falscher" Code (nicht im Speicher vorhanden) eingegeben wurde, wird das System für 60 Sekunden blockiert.
Signalisierungsart: Die Tastatur gibt einen **Beep**-Ton von sich und die beiden LED blinken 5 Sekunden lang.
- Wenn die Taste # während der Eingabe eines Codes gedrückt wird, wird dieser Code ignoriert. Daher muss der gesamte Code neu eingegeben werden.

Fehler-Signalisierung

Schnittstelle - rotes LED blinkt:

- Speicher voll
- Code vorhanden (im Speicherverfahren)
- Code nicht vorhanden (im Löschverfahren)

Tastatur - rotes LED blinkend

- begleitet von drei langsamen **Beep**-Tönen, Code vorhanden (im Speicherverfahren)
- Code nicht vorhanden (im Löschverfahren)
- begleitet von drei schnellen **Beep**-Tönen, falscher Code im Betriebsmodus.

Antes de dar inicio a la instalación, léase con atención este manual. En especial, véanse los dispositivos de seguridad dispuestos para el producto para poderlos utilizar con la máxima eficacia. **Antes de realizar la programación, leer atentamente las "NOTAS" que se indican en la página 46.** El uso de los productos y su destino para usos diferentes a aquéllos previstos y/o aconsejados, no ha sido probado por el fabricante, por tanto los trabajos ejecutados están sometidos a la total responsabilidad del instalador. Este manual se dirige a personas habilitadas para la instalación de "aparatos utilizadores de energía eléctrica" y exige el buen conocimiento de la técnica, realizada profesionalmente. El fabricante no se responsabiliza de los daños eventuales debidos al incumplimiento durante la instalación de las normas de seguridad actualmente vigentes.

Descripción

El sistema consta de dos elementos conectados entre sí vía cable:

- **DKS250T** teclado numérico para exteriores
- **DKS250R** interfaz para conexionado serie que alimenta también el teclado.

El teclado consta de una estructura metálica en zamak, antirroto, con barnizado de alta resistencia y botones cromados antidesgaste. Fácilmente instalable y provisto de un grado de protección **IP57** y un sistema de fijación antirroto con tornillos y llave especiales.

Está provisto de:

- LED rojo de señalización
- LED verde de señalización
- 10 botones numéricos (0-9)
- 1 botón de confirmación *
- 1 botón de anulación de la operación #
- 4 funciones de canal (A, B, C, D)
- chicharra de señalización sonora.

La interfaz está colocada en un receptáculo para interiores **IP20** y se conecta al teclado con un cable telefónico (o equivalente) con dos conductores **Ø 0,6 mm** y longitud máxima de **150 m**; está provista de botón de programación y dos LEDs (**L1** verde, **L2** rojo) de señalización visual.

Posibilidad de empleo

El sistema **DKS250** permite activar vía cable equipos eléctricos y electrónicos, facilitando la máxima seguridad y hallando el mejor empleo del mismo para el control de puertas y portones motorizados.

Número de códigos de usuario memorizables (máx. 6 cifras cada uno): 250
 Nr. de combinaciones de código: 1 millón
 Número de teclados que pueden conectarse en paralelo a una interfaz 3

CARACTERÍSTICAS TÉCNICAS

Alimentación interfaz DKS250R	12/24Vac-dc
Absorción:	
Teclado.....	6mA
Interfaz con teclado.....	31mA
Interfaz con teclado y relé activo	54mA
Potencia máxima conmutable del relé con carga resistiva (bombillas excluidas):	
Carga en ac/dc..60VA/24W.....	60VA/24W
Tensión máxima.....	30Vac-dc
Corriente máxima	1 A
Retardo en la activación del relé.....	80-100ms
Temperatura de funcionamiento teclado/interfaz	-10° ...+55°C

Dimensiones máximas

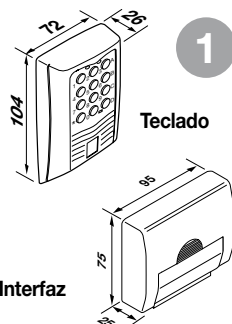

INSTALACIÓN DE LA INTERFAZ EN LA CAJA IP20

En función de la tipología y de las características de instalación es preciso determinar el punto de emplazamiento del sistema. La interfaz se debe colocar:

- en un ambiente interior (en contenedor estanco si se lo instala en el exterior);
- al amparo de choques y manejos;
- en una posición fácilmente alcanzable por el técnico, para las operaciones de mantenimiento.

Fijación:

- De pared, distancia entre centros **75 mm**, por medio de dos tornillos **M4** y espigas para agujeros de pared (no incluidas en nuestra provisión)
- En caja estanca, utilizando el biadhesivo suministrado de serie.

Conexión eléctrica interfaz



¡Cuidado! Alimentar la interfaz únicamente con una fuente de alimentación de seguridad. El uso de fuentes de alimentación no de seguridad puede ocasionar peligro.

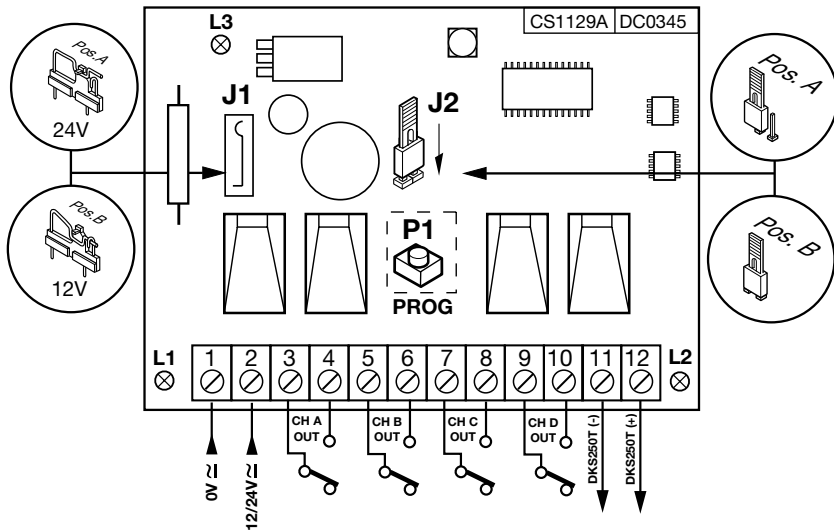

La interfaz (circuito impreso CS1129A/B) está provista de contenedor para interiores y caja de bornes de 12 vías con conexión eléctrica:

12V ac/dc entre los bornes 1-2 con el puente "J1" en posición "B",

24V ac/dc entre los bornes 1-2 con el puente "J1" en posición "A".

(L3 si alumbra cuando el aparato está alimentado)

La interfaz tiene cuatro relés cuyas salidas están marcadas respectivamente con CHA, CHB, CHC y CHD (sólo contacto N.A.).

- Predisponer el cable de conexionado que alimenta el teclado de códigos, en el cual se realiza la comunicación serie de los datos, en función de la distancia entre la interfaz y el teclado.
- Conectar los cables provistos de las conexiones rápidas: **FS1** negro con el borne "11", **FS2** rojo con el borne "12" (fig. 3b).

INSTALACIÓN DEL TECLADO EN EXTERIORES IP57

1) Pasar los cables de conexión "1" procedentes de la interfaz a través de la pared.

2) Perforar la pared hasta la distancia que se indica en la figura 3a (58 mm).

3) Introducir las espigas para agujeros de pared "2" que se entregan junto con el kit.

4) Bloquear la contraplaca "3" utilizando los tornillos "4" que se entregan junto con el kit.

5) Conectar las conexiones rápidas de los cables "1" con las conexiones rápidas del teclado "5" (fig. 3a-3b):
- **cable rojo** del teclado con el borne 12 de la interfaz
- **cable negro** del teclado con el borne 11 de la interfaz.

6) Por último, colocar el teclado (fig. 3b-3c) y bloquearlo en la contraplaca, utilizando el tornillo "S1" y la herramienta "K1" al efecto.

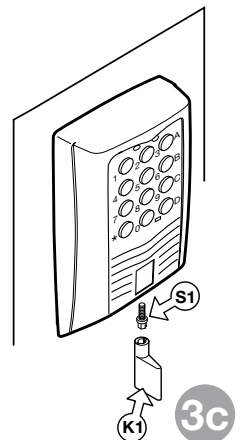
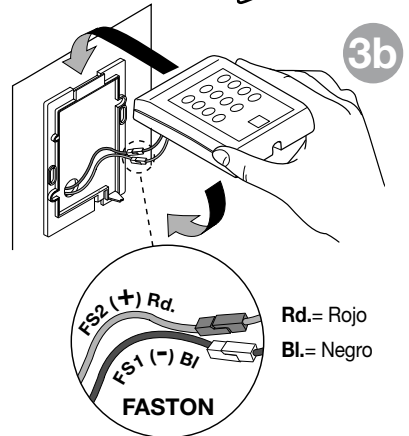
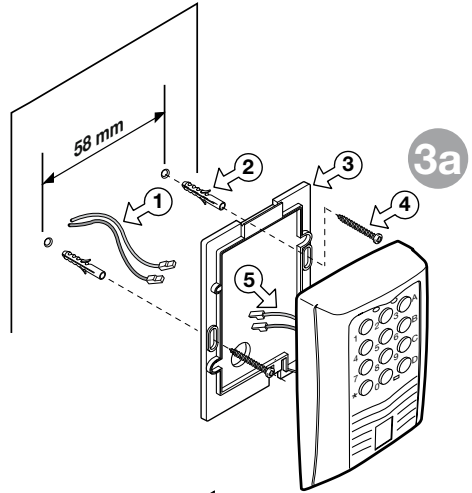

PROCEDIMIENTO PARA LA PROGRAMACIÓN



Antes de proceder con la primera memorización de los códigos, acordarse de anular enteramente la memoria.

1. Anulación total de la memoria

1a  Abrir el puente "J2" en la interfaz

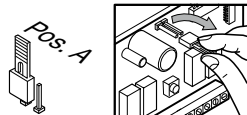

1b Pulsar cuatro veces, en secuencia, el botón "P1" en el interfaz y la cuarta vez mantenerlo pulsado seis segundos

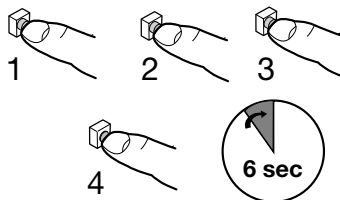

1c Los LEDs "L1" verde y "L2" rojo se ponen intermitentes y permanecen encendidos durante la anulación



1d El LED rojo "L2" se apaga y el LED verde "L1" se pone intermitente por algunos segundos y luego se apaga

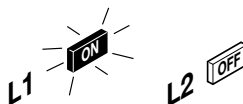

¡A este punto todos los códigos han sido anulados!

2. Registro del código de acceso a las funciones de programación en remoto con el teclado.

2a  Cerrar el puente "J2" en la interfaz

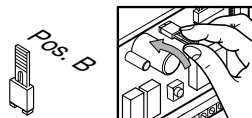



2b Pulsar el botón "P1" durante por lo menos 6 segundos



2c El LED rojo "L2" en la interfaz se enciende.

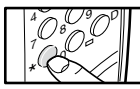

2d  Teclar -en el teclado- el código numérico elegido para habilitar el acceso a las funciones (máx. 6 cifras; por ej.: 1-2-3-4-5-6) y pulsar confirmar "*" 

2e  En la interfaz, el LED verde "L1" se pone intermitente y el LED rojo "L2" se apaga



¡La memorización del código de acceso ha sido realizada!

3. Memorización de los códigos y selección de las funciones

3a  Abrir el puente "J2" en la interfaz

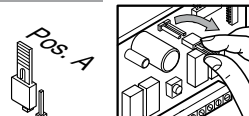

3b Pulsar el botón "P1" en la interfaz durante por lo menos 3 segundos.



3c El LED rojo "L2" en la interfaz se enciende.



¡A este punto, el procedimiento de memorización ha sido activado!

3d  Teclar -en el teclado- el código numérico por memorizar (máx. 6 cifras, por ej. 1-2-3-4-5-6) y pulsar confirmar "*".

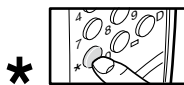

3e El teclado emite un bip por 2 segundos + LED verde encendido

El código ha sido aceptado y memorizado



3f Después de 13 segundos de haber confirmado el código, pulsar una o más funciones A-B-C-D en secuencia (por ej.: A-C)

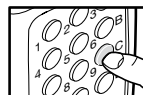

3g Pulsar confirmar "*" y el teclado emite un bip

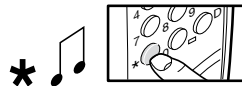

3h  En la interfaz, el LED verde "L1" se pone intermitente

**El código ha sido memorizado.
Las funciones han sido asignadas (por ej.: A-C).**

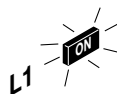

MODALIDAD DE FUNCIONAMIENTO





4. Memorización de los códigos desde posición remota

Si anteriormente no se había realizado el "Registro del código de acceso a la programación en remoto", realizar el procedimiento por entero (ref. 2, pág. 41).



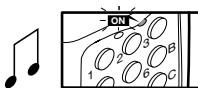

¡Atención! La memorización será posible sólo si el puente en el interfaz "J2" ha sido insertado.

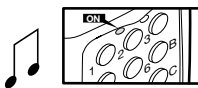
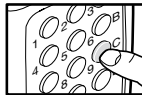
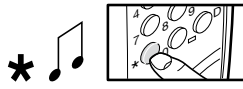
Si el "Registro del código de acceso a la programación en remoto" ha sido realizado:

- 4a**  Teclar, en el teclado, el código de acceso a la memorización y pulsar confirmar "*****" 
- 4b** El teclado emite un **bip** y los LEDs **rojo** y **verde** se encienden (a continuación, el LED verde se apaga) 
- ¡Función activada!**
- 4c**  Teclar, en el teclado, el nuevo código numérico por memorizar (máx. 6 cifras; por ej. 1-2-3-4-5-6) y pulsar confirmar "*****" 
- 4d** El teclado emite un **bip** por 2 segundos + LED verde encendido 
- El código ha sido aceptado y memorizado.**
- 4e** Después de 13 segundos de haber confirmado el código, pulsar una o más funciones A-B-C-D en secuencia (por ej.: **A-C**). 
- 4f** Pulsar confirmar "*****" y el teclado emitirá un **bip** 
- Las funciones han sido asignadas** (por ej.: **A-C**)

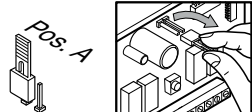
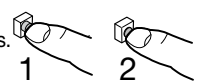
5. Anulación de un solo código

- 5a**  Abrir el puente "J2" en la interfaz 
- 5b** Pulsar dos veces, en secuencia, el botón "**P1**" en el interfaz y la segunda vez mantenerlo pulsado tres segundos.  

5c En la interfaz, los LEDs verde "L1" y rojo "L2" se encienden
¡Dispositivo preparado para anular!



5d  Teclar el código numérico por anular y pulsar confirmar "*"



5e  En la interfaz, el LED verde "L1" se pone intermitente
¡Código anulado!

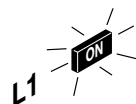

6. Anulación de un solo código desde posición remota









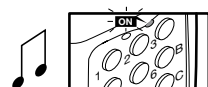

¡Atención! La anulación será posible sólo si el puente "J2" ha sido conectado

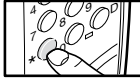
6a  Teclar la siguiente secuencia **#*(código para cancelar)*#**
(por ejemplo si se quiere cancelar el código 112233, marcar **#*112233*#**)

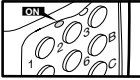
6b El teclado emite un bip por 2 segundos
+ LED verde y LED rojo encendidos
¡Código anulado!

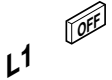

7. Activación del código de usuario

- 7a**  Teclar, en el teclado, el código numérico de usuario y pulsar confirmar "*****" 
- 7b** El teclado emite un **bip** por 2 segundos + LED verde encendido  
- 7c**  El LED verde "**L1**" se enciende en la interfaz 
¡Código aceptado!
- 7d**  Pulsar A-B-C o D en la columna de la derecha del teclado (por ej.: "**C**")  
¡Activación realizada!
- 7e** Se emitirá un **bip** después de 5 segundos de inactividad del teclado. El LED verde se apaga y se sale de la modalidad.  

NOTAS

- La inserción de un código de más de 6 cifras cancela la operación en curso.
Tipo de señalización: el teclado emite un **bip**.
- El tiempo a disposición entre la inserción de una cifra y la otra es de 5 segundos.
Transcurridos los segundos a disposición, la operación se cancela.
- "Memorización de los códigos": tras haber memorizado el código, después de 20 segundos, se sale automáticamente del procedimiento.
Tipo de señalización: el LED rojo del teclado se pone intermitente, se emiten **6 bips** en secuencia.

Advertencias

- Antes de proceder con la primera memorización de los códigos, anular enteramente la memoria.
- Puede registrarse un solo código de acceso a la memorización en remoto.
Para cambiarlo es suficiente repetir el procedimiento y registrar el nuevo código deseado.
- La total anulación de la memoria, anula también el código de acceso a la memorización en remoto.
- Después de teclear cinco veces consecutivas un código "erróneo" (no presente en la memoria), el sistema se inhabilita por 60 segundos.
Tipo de señalización: el teclado emite un **bip** y los dos LEDs se iluminan de forma intermitente por 5 segundos.
- Si se pulsa el botón # durante el tecleo de un código, dicho código será ignorado; se deberá entonces teclear de nuevo el código por entero.

Señalizaciones de error

Interfaz - LED rojo intermitente:

- memoria completa
- código existente (en memorización)
- código inexistente (en anulación)

Teclado - LED rojo intermitente

- acompañado de tres **bips** lentos, código existente (en memorización)
- código inexistente (en anulación)
- acompañado de tres **bips** rápidos, código erróneo en modalidad de funcionamiento

NOTES

NOTES



CARDIN ELETTRONICA spa

Via Raffaello, 36- 31020 San Vendemiano (TV) Italy

Tel:

+39/0438.404011-401818

Fax:

+39/0438.401831

email (Italy):

Sales.office.it@cardin.it

email (Europe):

Sales.office@cardin.it

Http:

www.cardin.it